

**Magnolia Editions** has a long tradition of producing limited editioned prints using a wide range of processes and tools, from traditional intaglio etching techniques to the latest digital technologies. We work with artists attracted to the collaborative process of image making. By working side-by-side with Magnolia Editions' staff, the artist can ensure that the final product remains faithful to his or her vision.

**NOTE:** IN GENERAL, WE DO NOT ACCEPT WORK DROPPED OFF TO BE PRINTED AND PICKED UP LATER - WE ASK THE ARTIST TO BE PRESENT DURING PRINTING.

Typically, the charges an artist incurs for a digital printing project are based on two factors. The first involves the computer time/services (editing, scanning, etc) necessary to prepare an image for printing. The second involves the cost of materials & printing: the paper (or canvas, mylar, etc) used to proof and/or print the image.



Canon iPF9000 printer at Magnolia Editions.

**PLEASE NOTE:** Magnolia Editions uses the highest quality inks, papers, and materials available. The acrylic ink for our UV-cured flatbed printer is sourced from Fuji-Sericol; we know of no longer lasting, higher quality ink. Although we use the highest standards of craftsmanship and make every effort to ensure that our prints are permanent and archival, Magnolia Editions assumes no responsibility for fading of prints over time.

## COMPUTER TIME & SERVICES

### Digital editing, layout and design

All computer services -- editing, layout, design, resizing and cropping, etc -- **\$150 an hour.**

### Scanning from original artwork

For artists with flat art measuring 11" x 17" or smaller, Magnolia Editions can scan the artwork in-house at \$25 per scan, up to 80Mb RGB, or \$35 for between 80 and 120Mb RGB.

For digital image capture of original work larger than 11" x 17", we recommend Ben Blackwell, who uses a BetterLight scan back on a 4 x 5" camera. His studio is at the UC Berkeley Museum. Phone: 510.387-5473

**NOTE:** A 100MB FILE CAN PRODUCE A PIGMENTED INKJET PRINT APPROXIMATELY 30" x 40". LARGER PRINTS NEED MORE MEGABYTES.

### Scanning from transparencies

For artists wishing to work from transparencies, there are several options. A fast but low resolution flat bed 4" x 5" scan can be made in-house for \$25 per 80Mb scan.

Alternately, high-quality 4" x 5" drum scans can be created by a trusted Magnolia Editions associate at the following rates, which include shipping and handling (allow one week):

**100 mb: \$50    200 mb: \$70    300 mb: \$100    900 mb: \$300**

## DIGITAL PIGMENTED INKJET PRINTS: (Canon 9000 - 12 colors)

Our **Canon large format printer** uses rolls of media up to 60 inches wide and up to 66 feet long; prints can be any size so long as one dimension (height or width) does not exceed 60". It uses 12 colors of pigmented ink. In addition to the common inks (cyan, light cyan, magenta, light magenta, yellow and two blacks), this technology uses two light grays and introduces red, green, and blue, creating the finest detail and largest color gamut we have ever seen in inkjet printing.

### Resolutions:

**Standard:** 1200 x 1200dpi - 6 pass

**High:** 2400 x 1200dpi - 8 pass

**Highest:** 2400 x 1200dpi - 16 pass -Increases price 10%

### PRICING:

#### Art Paper 190 Grams and lighter weights:

- 36 in. roll: \$40 - per linear foot
- 44 in. roll: \$48 - per linear foot
- 47 in. roll: \$52 - per linear foot (kozo only)
- 52 in. roll: \$58 - per linear foot

#### Heavy Weight Art Paper 200 to 330 Grams:

- 24 in. roll: \$32 - per linear foot
- 36 in. roll: \$48 - per linear foot
- 44 in. roll: \$58 - per linear foot
- 52 in. roll: \$70 - per linear foot
- 60 in. roll: \$80 - per linear foot

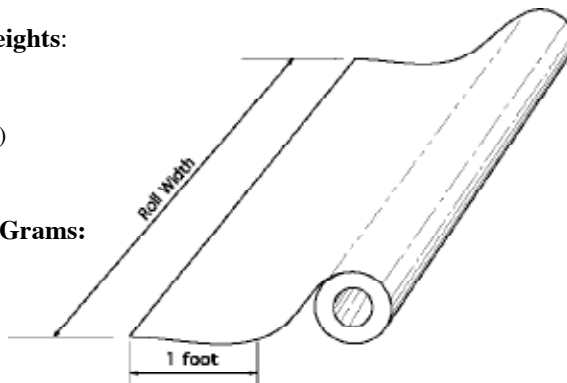

#### Canvas and Backlit film:

- 36 in. roll: \$45 - per linear foot
- 44 in. roll: \$55 - per linear foot
- 50 in. roll: \$62 - per linear foot
- 54 in. roll: \$67 - per linear foot
- 60 in. roll: \$75 - per linear foot

#### Heavy Weight Poster paper

Standard Resolution:

- 36 in. roll: \$30 - per linear foot
- 42 in. roll: \$35 - per linear foot
- 54 in. roll: \$45 - per linear foot
- 60 in. roll: \$50 - per linear foot

**UV FLATBED PRINTER:** Printing area: 4' x 8' up to 1.75" thick

Using a durable pigment/solvent ink cured with UV light, this printer prints on almost anything flat. The media is stationary, held down with a vacuum, and can be overprinted multiple times in perfect registration.

**Media printed to date:** Western paper, Japanese paper, amate (bark paper), book cloth, leather, gessoed panel, raw wood, old weathered wood, glass, mirror, Plexi, mylar, copper, aluminum, prepared aluminum, raw canvas, raw linen canvas, gessoed canvas, and sound board.

**Machine time: \$100 per hour**

**Paper, canvas, cloth, aluminum: \$15 per sq. ft.** (user supplies media)

**Glass: \$25 per sq. ft.** (user supplies media)

Please bring a **200 DPI flat TIFF** to size (ie, as big as you'd like the printed image to be.)

**INKJET PRINT MEDIA:**

- Gessoed (environmentally friendly) plywood 3/8" 4' x 8' \$150
- Hahnemuhle Photo Rag (308g) – roll widths: 36", 44"
- Somerset Velvet (190g & 330g) – roll widths: 24" 36", 42"
- Diamond Jet Heavy Weight – roll widths: 36", 44", 52", 60"
- Moab Entrada Natural\* (190g & 300g) – roll widths: 36", 44", 50"
- Water Resistant Matte Canvas – roll widths: 36", 44", 50", 54", 60"
- Illford Photo gloss – roll widths: 36"
- Illford Photo – roll widths: 36"
- Japanese Kozo – roll widths: 47"
- Laid book paper – roll widths: 36"
- Textured watercolor paper – roll widths: 36"

**DISCOUNTS**

**Quantity discounts:**

- 10 - 24 linear feet (30 sq ft): 10% off
  - 25 - 49 linear feet (75 sq ft): 15% off
  - 50+ linear feet(150 sq ft): 20% off
- For larger orders, please call for an estimate.

**Student discount:**

College art students (with student I.D.) receive a 25% discount.

**UV ACRYLIC COATINGS:**

Gloss and matte acrylic coatings:  
Pricing to be determined based on job size.



**SELF SERVICE Digital Equipment**

**LCD digital tablet:** (draw directly on the screen)

At Magnolia, if you choose to do the editing yourself, you will have access to a Wacom Cintiq 21 inch interactive pen display for digital editing. It combines the advantages of an LCD monitor with tablet technology. By using a pressure sensitive pen directly on the screen, you can work quickly and naturally. The Cintiq features ExpressKeys™ and Touch Strips right at your fingertips for convenient keyboard shortcuts, scrolling, zooming, brush size control, and more.

**Hourly rate: \$60**



Flatbed UV Printer - 4'x 8' up to 1.75" thick

- Backlit film – roll widths: 36", 60"
- Mylar – roll widths: 24"
- Cotton twill – roll widths: 36", 42"
- Silk – roll widths: 36", 42", 50" (Priced as Heavy Weight Art Paper)

**Archiving jobs and burning CDs and DVDs**

Although we do store projects on our hard drives for a period of time following a job, an archived CD is a much safer bet. We can burn a CD/DVD at the completion of a project for you. **CD: \$10 DVD: \$20**

**ADDITIONAL SERVICES**

**Packaging:**

- Flats 20 x 16": \$7
- Flats 30 x 22": \$12
- Flats 36 x 24": \$16
- Tubes: \$15
- Plastic Tube Sleeve: No charge

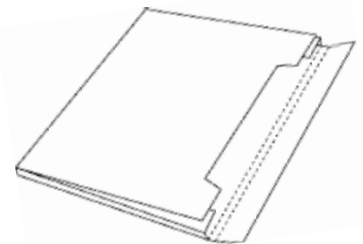

**Custom packaging \$45 per hour** plus cost of materials. We prefer you bring your own portfolio or recycled flats for transporting finished prints. Unless otherwise stated, our packaging materials are not acid-free and are not recommended for long-term art storage.

**Stencil cutter:** (20 inch vinyl cutter)

Any design done in Illustrator including text can be cut and used as wall text, airbrush stencil, signage, etc.

**\$18 per linear foot**

**GUNNAR 3001** (Computerized mat cutter: 47" x 35" bed, 90° & 45° cuts)

Custom box design and cutting - **\$100 per hour** plus materials.  
Super fast clean cuts.

Name: \_\_\_\_\_ Phone: \_\_\_\_\_ Email: \_\_\_\_\_

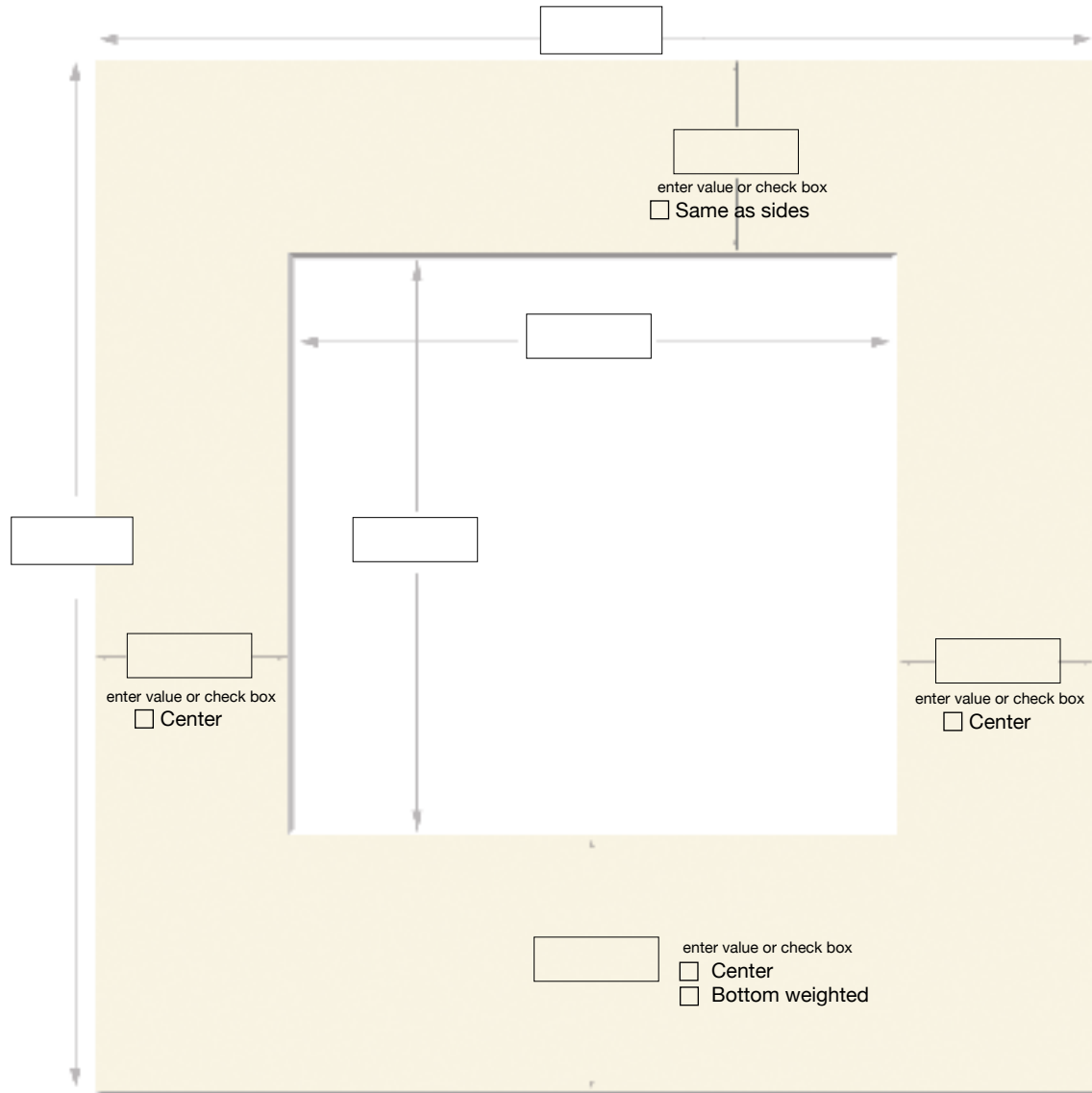

Mat color:	<input type="checkbox"/> Warm White	<input type="checkbox"/> Antique White	
Mat Weight:	<input type="checkbox"/> 2Ply	<input type="checkbox"/> 4Ply	<input type="checkbox"/> 8Ply
Backing:	<input type="checkbox"/> 2Ply	<input type="checkbox"/> 4Ply	<input type="checkbox"/> 8Ply
Hinging (\$1.25):	<input type="checkbox"/> Long Side	<input type="checkbox"/> Short Side	<input type="checkbox"/> None

Museum Board Quantity Discounts:

Museum Board 32 x 40	1-3	4-9	10+
2 ply	\$7.85	\$6.50	\$6.10
4 ply	\$17.90	\$14.15	\$12.25
8 ply	\$33.00	\$28.50	\$24.75

Cutting Charge Quantity Discounts: (per aperture)

1-9	\$5.00	10-29	\$4.50	30-99	\$4.00	100+	\$3.50
-----	--------	-------	--------	-------	--------	------	--------

Custom box design and cutting - \$100 per hour plus materials

Price and availability subject to change. ©2010 Magnolia Editions, Inc.