

Magnolia Editions has a long tradition of producing limited editioned prints using a wide range of processes and tools, from traditional intaglio etching techniques to the latest digital technologies. We work with artists attracted to the collaborative process of image-making. The artist can ensure that the final product remains faithful to their vision by working side-by-side with Magnolia Editions' staff.

Note: generally, we do not accept work dropped off to be printed and picked up later - we ask the artist to be present during printing.

Typically, the charges an artist incurs for a digital printing project are based on two factors. The first involves the computer time/services (editing, scanning, etc.) necessary to prepare an image for printing. The second consists of the cost of materials & printing: the paper (or canvas, mylar, etc.) used to proof and print the image.

COMPUTER TIME & SERVICES

Digital editing, layout and design

All computer services:

Editing, layout, design, resizing and cropping, etc.

Hourly rate: \$95

Scanning from original artwork

For artists with flat art measuring 11" x 17" or smaller, Magnolia Editions can scan the artwork in-house for **\$35 per scan**.

Scanning from transparencies

For artists wishing to work from transparencies, there are several options. A flat bed 4" x 5" scan can be made in-house for **\$35 per scan**.



Canon IPF Pro 4000 & IPF 9400 - 12 color water-based inkjet printers at Magnolia Editions.

PLEASE NOTE: Magnolia Editions uses the highest quality inks, papers, and materials. We know of no longer-lasting or higher-quality ink. Although we use the highest standards of craftsmanship and make every effort to ensure that our prints are permanent and archival, Magnolia Editions assumes no responsibility for fading of prints over time.

Photographing original artwork

For artists wishing to have their artwork(s) photographed we use a medium format digital Fujifilm camera which is capable of taking a 100 megapixel image in a single shot or a 400 megapixel image by combining 16 photos into a single image. Like all our services the artist must be present and is responsible for the safety of their original work(s).

Hourly rate: \$95

DIGITAL PIGMENTED INKJET PRINTS: (Canon ipf 9400 and Canon Pro 4000- 12 colors)

Our **Canon large format printers** use rolls of media up to 60 inches wide and 66 feet long; prints can be any size so long as one dimension (height or width) does not exceed 60". It uses 12 colors of pigmented ink. In addition to the standard inks (CMYK), this technology uses light cyan, magenta, light magenta, two blacks, and two light grays. The introduction of red, green, and blue creates the finest detail and most extensive color gamut we have ever seen in inkjet printing.

PRICING:

Heavy Weight Art Paper 200 to 330 Grams:

24 in. roll: **\$40 - per linear foot**

36 in. roll: **\$60 - per linear foot**

44 in. roll: **\$73.33 - per linear foot**

54 in. roll: **\$90 - per linear foot**

60 in. roll: **\$100 - per linear foot**

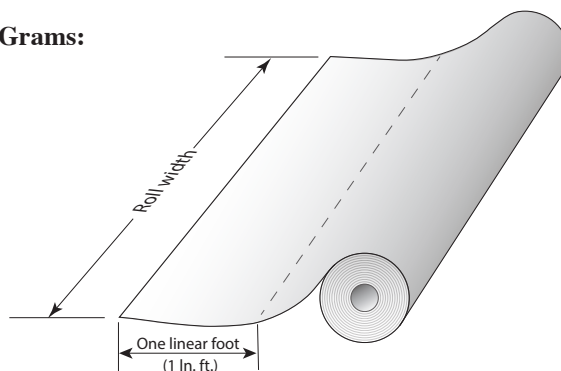

Canvas:

36 in. roll: **\$48 - per linear foot**

44 in. roll: **\$58 - per linear foot**

54 in. roll: **\$72 - per linear foot**

60 in. roll: **\$80 - per linear foot**



Flatbed acrylic UV Printer – 10'x 8' up to 1.75" thick

UV FLATBED PRINTER: Printing area: 8'x 10' up to 1.75" thick

This printer prints on almost anything flat using a durable pigment acrylic ink cured with UV light. The media is stationary, held down with a vacuum, and can be overprinted multiple times in perfect registration.

Media printed to date: Western paper, Japanese paper, amate (bark paper), book cloth, leather, gessoed panel, raw wood, old weathered wood, glass, Plexiglass, acrylic, drywall, rubber, mylar, steel, copper, aluminum, prepared aluminum, raw canvas, raw linen canvas, gessoed canvas, stone, Dibond, foam core, matt board, and soundboard.

Machine time is an Hourly rate of \$120

Most materials without white: **\$18 per sq. ft.**
(user supplies media; **\$22/sq. ft** for double pass)

DISCOUNTS

Quantity discounts:

10 - 24 linear feet (30 sq ft): 10% off

25 - 49 linear feet (75 sq ft): 15% off

50+ linear feet(150 sq ft): 20% off

For larger orders, please call for an estimate.

Student discount:

College art students (with student I.D.) receive a 20% discount.

Other Digital Equipment

Laser cutter: (48" x 28" bed)

Grayscale, rastered Illustrator images can be etched into glass, stone, etc, or vector-based Illustrator files can be used to cut paper, acrylic, etc., into a particular shape.

Hourly rate: \$150

Most materials with white ink: **\$24 per sq. ft.** (user supplies media)
Square footage price for our UV flatbed is based partially on the type of media the user-supplied, ranging from **\$18/sq. ft. - \$25/sq. ft.**

Archiving digital jobs is the client's responsibility:

We cannot guarantee storage of clients' digital projects on Magnolia hard drives following a project. We are not a storage solution. Keeping the original and modified files is the clients' responsibility. We recommend Dropbox or other cloud storage solutions.

ADDITIONAL SERVICES

Custom packaging: We prefer you bring your portfolio or recycled flats for transporting finished prints. Our packaging materials are not acid-free and are not recommended for long-term art storage unless otherwise stated.

Hourly rate: \$80 plus the cost of materials

CNC Router: (48" x 96" bed)

We can cut many different types of materials on our CNC router including but not limited to many different types of wood, and different plastics,

Hourly rate: \$120